

MODEL 878 WTP

GANTRY MOUNTED INTERMODAL TOP LIFT SPREADER
FOR LADEN CONTAINER HANDLING



Standard supply includes:

- ◆ Mounting arrangement to fit the gantry
- ◆ Four pendular ISO twistlocks
- ◆ Lifting eyes near twistlocks
- ◆ Mechanical pile slope (MPS)
- ◆ Hydraulic powered pile slope (PPS) via gantry
- ◆ Hydraulic telescoping
- ◆ Hydraulic slew and reach via connection to gantry
- ◆ Hydraulic stops
- ◆ Hydraulic leg folding
- ◆ Hydraulic clamp and unclamp
- ◆ Solenoid valves for all hydraulic functions
- ◆ Four foldable piggyback legs in an automatic sequence with block stacking
- ◆ Electrical and mechanical twistlock protection and indication system
- ◆ Electric telescoping system protection
- ◆ Electrical protection indication system for trailer handling
- ◆ Lift interrupt signal
- ◆ LED-indication lights
- ◆ LED-work lights
- ◆ WTP
- ◆ North American trailer handling

ELME Spreader Model 878 WTP is a container and trailer handling spreader for handling of laden ISO, WTP and US-domestic containers weighing up to 40 tonnes. 878 WTP is designed for use under a gantry at the front of a lift truck.

The strong and basic concept offers distinct advantages, such as two parallel telescopic beams, assuring max overlap. The beam sections are dimensioned to absorb not only the vertical, but also the very considerable horizontal forces.

TWISTLOCK SYSTEM

The twistlock system is manufactured in a rugged design and is well-proven since many years. 878 WTP has hardened, pendulling ISO twistlocks, hydraulically activated with electrical and mechanical interlocking against faulty locking and unlocking.

GANTRY MOUNTING WITH MECHANICAL PILE SLOPE

Gantry mounting is used for lift trucks, dedicated to container handling only. Four telescopic hangers connect the spreader to the gantry. Gravity assures the level position of the spreader, with or without load. However, the hangers will allow the spreader to automatically adapt to containers on trailers or on uneven ground.

PIGGYBACK LEGS SYSTEM

The leg arrangement is done according to the ELME design system which is a load clamping system that involves all four foldable piggyback legs in an automatic sequence. Thanks to this feature the spreader can be lowered between containers that are block stacked front to front and side to side. Integrated in each leg/

foot is a clamping sensor that signals to the driver that the trailer is ready to be lifted. The folding is sequential as standard but outside of the 30ft-position it is parallel for reduced folding/unfolding time.

TELESCOPING, SLEW, REACH AND SIDESHIFT SYSTEM

Telescoping is powered by one hydraulic cylinder inside each beam. The slew and reach motions are possible thanks to two hydraulic cylinders that connect the spreader to the gantry. By powering either one or both cylinders, the slew and reach functions are activated. A third cylinder between spreader and gantry provides the sideshift motion.

WTP-SYSTEM

The WTP option built into the spreader endbeams allows the operator to hydraulically change the twistlock positions to handle ISO and US-domestic containers as well as WTP containers.

CONTROL AND PROTECTION SYSTEM

Electrical systems monitor the state of the spreader at all times. Indicator lights advise the operator when the spreader is correctly seated, locked or not locked and in intermodal mode, clamped or not clamped. The signals are preconditions for the important protection functions of the spreader such as twistlock activation, telescoping, piggyback legs and lift interrupt.

MODEL 878 WTP

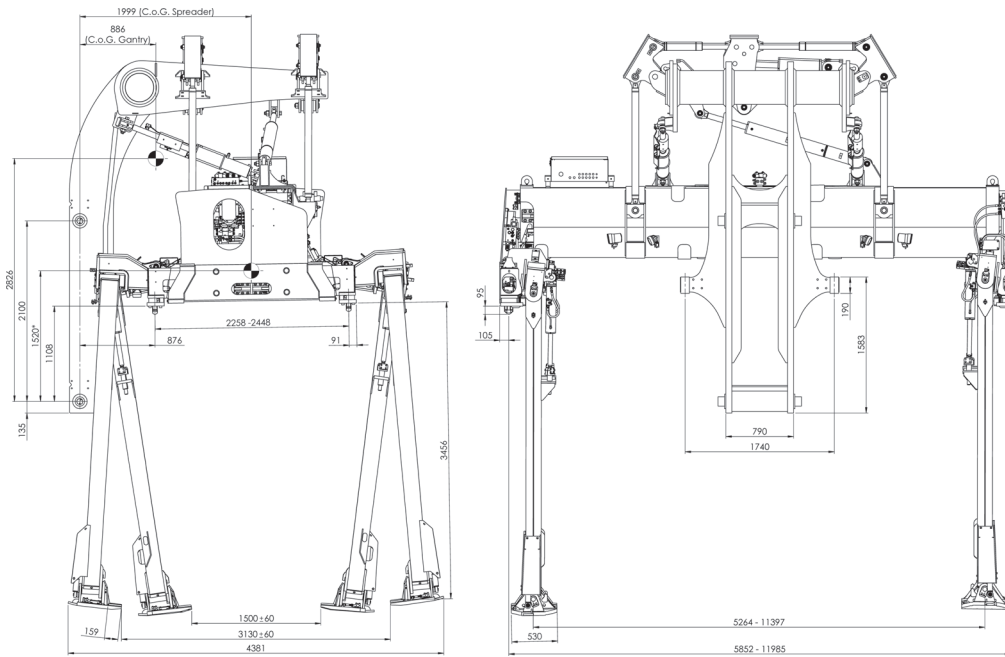

878.

TECHNICAL SPECIFICATIONS

Type of application	Gantry mounted
Type of lifting system	Four vertical twistlocks
Spreader weight (TW)	13 000 kg without extra equipment
Lifting capacity (SWL), spreader	40 tonnes ± 10 % eccentric load
Lifting capacity (SWL), piggyback	40 tonnes ± 10 % eccentric load
Lifting capacity (SWL), lifting eyes	4 x 10 tonnes
Twistlock	ISO pendular 20 mm
WTP-option	< 5 sec.* ISO pos. 2 958 mm WTP pos. 2 448 mm
Telescopic positions	20, 30 and 40ft
Telescoping speed, 20-40ft	< 25 sec.*
Telescoping speed, 40-20ft	< 25 sec.*
Slew	± 6°
Reach	± 120 mm
Sideshift, ± 400 mm	7 sec.*
Mechanical pile slope (MPS)	± 3°
Power pile slope (PPS)	± 6°
Legs clamping distance, min / max	1,500 ± 60 mm / 3,130 ± 60 mm
Legs centre distance, min / max	5,264 - 11,397 mm
Hydraulics, operating pressure up to	140 bar
Hydraulics, flow	40-60 L/min
Electric - control voltage	24 VDC
Colour	Black grey RAL 7021
Paint thickness	150 µ

* Calculated speed at 20° C



Piggyback foot, North American Standard.



Twistlock and lifting eye.

All specifications are subject to change without notice. A list of options enables you to adapt the product more precisely to your needs and further information is available on request.

HEAD QUARTER AND PRODUCTION ELME Spreader AB

Phone +46 10 222 18 00
Email sales@elme.com
Website www.elme.com

SALES AND SPARE PARTS ELME Spreader Trading (Shanghai) Co., Ltd

Phone +86 21 5169 8922
Email sales.cn@elme.com

SPARE PARTS ELME Americas Inc.

Phone +1 731 588 02 20
+1 731 332 09 29
Email sales.us@elme.com

Visit www.elme.com for details, spare parts and more products.

ELMETM
Swedish Spreader Systems