

# MODEL 582LS INNOVATION<sup>[E]</sup>

FOR EMPTY CONTAINER HANDLING  
WITH LIFT TRUCKS



## Standard supply includes:

- ◆ Integrated mounting to fit the truck
- ◆ Powered pile slope (PPS)
- ◆ Mechanical pile slope (MPS), floating function in the end-posts
- ◆ Four hydraulic horizontal ISO twistlocks
- ◆ Hydraulic telescoping
- ◆ Hydraulic sideshift
- ◆ Solenoid valves for all hydraulic functions
- ◆ Electrical and mechanical twistlock protection system
- ◆ Electric twistlock indication
- ◆ Electric telescoping protection system
- ◆ Lift interrupt signal
- ◆ 2x6 LED indication lights
- ◆ 4x LED work lights (1000 lumen/light)

**The ELME Spreader Model 582LS INNOVATION is the New Generation telescopic side lift spreader with 11 tonnes capacity for handling two empty ISO/reefer containers simultaneously. The containers are engaged by four horizontal twistlocks inserted into the side apertures of the container's top and lower corner castings.**

The spreader is designed to be integrated in the mast of a forklift truck and can handle one or two ISO/reefer and Binnencontainers in 20 to 40ft. Special for 582LS INN. is that it can double handle 45ft containers in 40ft's corner castings and drive in free speed.

## INNOVATIVE DESIGN

INNOVATION's unique 11 tonnes capacity designed for heavy duty double handling applications, combined with handling eccentric load, makes it possible to handle double reefer containers with the refrigeration units aligned.

The new and improved design implies a reinforced spreader with an increased structural strength, enhanced durability, beneficially designed Power pile slope (PPS), optimized hydraulic system, increased visibility for the driver and numerous other improvements for an outstanding functionality.

## TWISTLOCK SYSTEM

582LS INN. has hardened ISO quick exchange twistlocks, hydraulically activated and mechani-

cal interlocking against faulty locking and unlocking. An ELME patent covers the innovative horizontal twistlock principle which offers the following features:

- ◆ Four purposely designed twistlocks enter the side apertures of the containers top and bottom corner castings, locking the spreader onto the containers positively and safely.
- ◆ Upper twistlocks are extendable/retractable to ensure pick up from a misaligned container stack.
- ◆ 582LS INNOVATION's width is adapted to the dimensions of the container, which means that all containers can be fully blockstacked and still remain accessible.

## CONTROL AND PROTECTION SYSTEM

The ELME Neuron CAN bus system, designed for maximum robustness, monitors the state of the spreader at all times. Indicator lights advise the operator when the spreader is correctly seated, locked or not locked. Each signal is a precondition for the important protection functions of the spreader such as twistlock activation, telescoping and lift interrupt.

# MODEL 582LS INNOVATION<sup>[E]</sup>

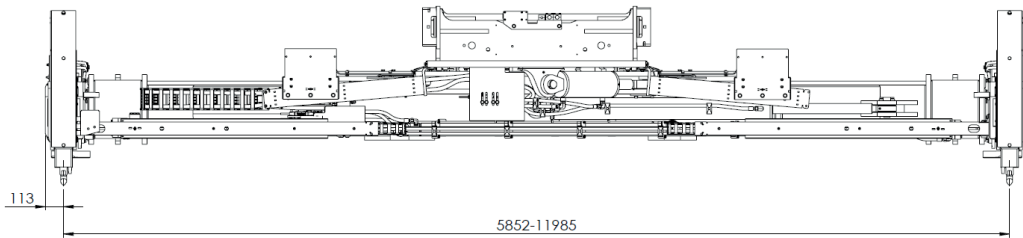
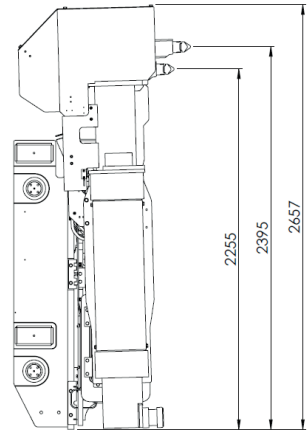
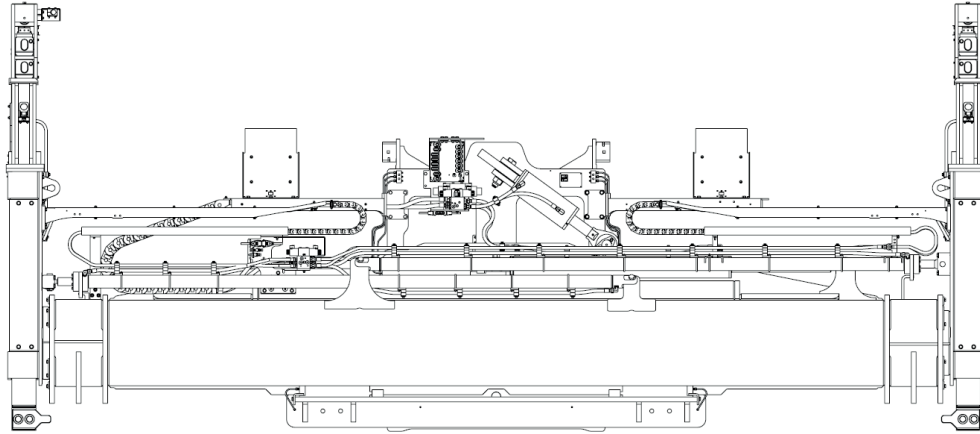

## TECHNICAL SPECIFICATIONS

Type of lifting system	Four horizontal twistlocks
Type of stacking	Normal and block stacking
Spreader weight (TW)	4 600 kg
Carriage weight (PPS)	Approx. 1 900 kg
Lifting capacity (SWL)	11 tonnes
Telescopic positions	20 and 40ft
Telescoping speed, 20-40ft	< 12 sec.*
Telescoping speed, 40-20ft	< 14 sec.*
Sideshift	± 600 optional ± 400 mm
Mechanical pile slope (MPS), vertical floating end-posts	At 20ft position: approx. 200mm At 40ft position: approx. 200mm
Powered pile slope (PPS)	± 6°
Hydraulics, operating pressure up to	140 bar
Hydraulics, flow	Max. 60 L/min
Electric - control voltage	24 VDC
Communication	CAN 2.0B
Colour	Black grey RAL 7021

\* Calculated speed at 60 L/min

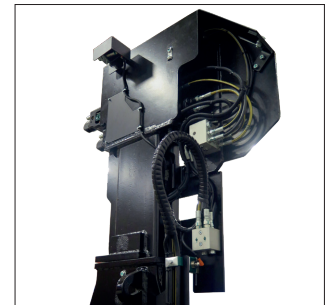

Improved design with built-in cabling and larger bending radius for hydraulic hose between pocket and end-post.



582LS INNOVATION head.

All specifications are subject to change without notice. A list of options enables you to adapt the product more precisely to your needs and further information is available on request.

### HEAD QUARTER AND PRODUCTION

#### ELME Spreader AB

Phone +46 10 222 18 00  
Email sales@elme.com  
Website www.elme.com

### SALES AND SPARE PARTS

#### ELME Spreader Trading (Shanghai) Co., Ltd

Phone +86 21 5169 8922  
Email sales.cn@elme.com

### SPARE PARTS

#### ELME Americas Inc.

Phone +1 731 588 02 20  
Email sales.us@elme.com

For details, spare parts and more products, visit [www.elme.com](http://www.elme.com).

**ELME**<sup>TM</sup>  
Swedish Spreader Systems