

MODEL 953

PIGGYBACK SLAVE ATTACHMENT



Standard supply includes:

- ◆ Mounting arrangement to fit the spreader
- ◆ Four foldable grapple legs in an automatic sequence
- ◆ Hydraulic leg folding
- ◆ Hydraulic clamp and unclamp
- ◆ Solenoid valves for all hydraulic functions
- ◆ Electrical protection and indication system for trailer handling
- ◆ Lift interrupt signal

ELME Piggyback slave attachment 953 is a removable unit under any 20ft ISO container spreader – dedicated for the handling of trailers, swap bodies and bottom lift containers.

The typical property of a slave attachment is to be easily attachable and detachable. It is also its main advantage and 953 is the given choice where container handling equipment is already in use and the need for bottom lifts arises.

953 is the economic choice at a terminal with relatively few bottom lifts and a desire to create flexibility in a fleet of container handling machines by switching from machine to machine.

GRAPPLE LEGS SYSTEM

The leg arrangement is done according to the ELME patented system which is a load clamping system that involves all four foldable grapple legs in an automatic sequence. Thanks to this feature the spreader can be lowered between containers that are block stacked front to front and side to side.

The feet are designed according to European standard and made of Strenx® 900E material (meets S 890 QL) to extend life time. Sensors (integrated in the feet) detect when the trailer is clamped and send signals to the indication system. To avoid unclamping, a signal is also sent as soon as the container/trailer is lifted off the ground.

HYDRAULIC FUNCTIONS

953 has two hydraulic functions; clamp/unclamp and fold/unfold of legs. Only one hydrau-

lic supply group is needed, as all functions are controlled through solenoid valves on the attachment.

INSTALLATION, CONTROL AND PROTECTION SYSTEM

Quick-change couplings and plug/socket connectors are used to hook up the attachment to the truck or to the spreader. When used under spreaders it is recommended to use a system, developed by ELME, eliminating the need for any adaptations to the truck.

Hydraulically and electrically, the spreader is disconnected from the truck and plugged into the slave attachment instead. The hoses and cables from the slave attachment are plugged into the connectors on the truck or on the spreader. The spreader functions locking/unlocking are then used for leg folding and clamping respectively.

Truck indicator lights advise the operator when the piggyback slave attachment is correctly seated, clamped or not clamped. The system ensures that the twistlocks connecting the spreader to the slave attachment cannot be opened inadvertently.

MODEL 953

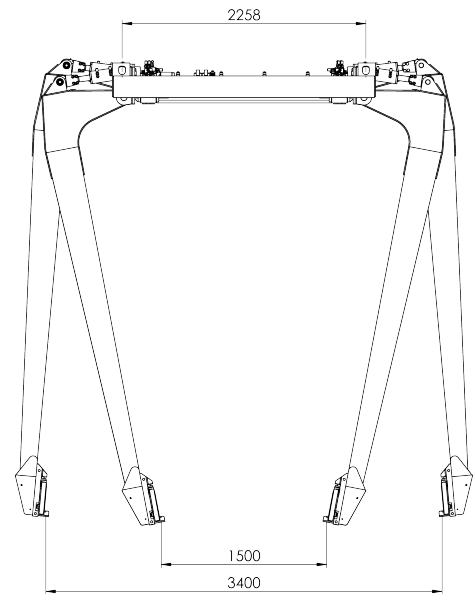
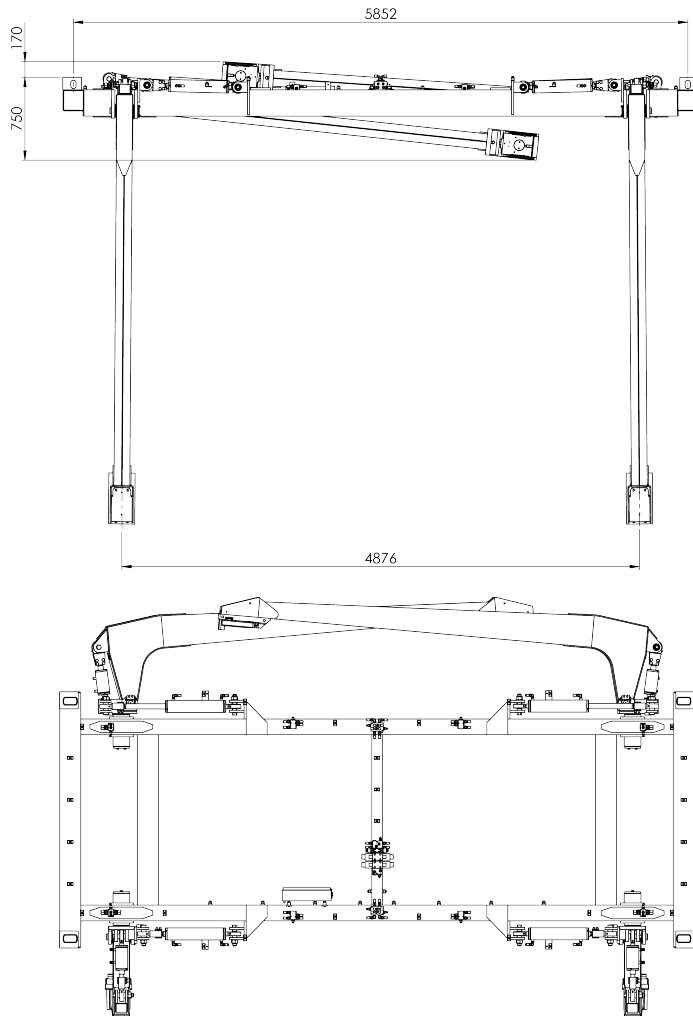

TECHNICAL SPECIFICATIONS

Type of lifting system	Twistlocks in 20ft position
Piggy back weight (TW)	3 600 kgs without extra equipment
Lifting capacity (SWL), piggy back	36 tonnes ± 10 % eccentric load
Lifting system	Corner castings at 20ft position
Grapple leg length	3 600 mm
Leg clamping distance, min	1,766 ± 60 mm
Leg clamping distance, max	3,200 ± 60 mm
Leg centre distance, min	4,876 mm
Hydraulics, operating pressure up to	140 bar
Hydraulics, flow	40-60 L/min
Electric - control voltage	24 VDC
Colour	Black grey RAL 7021
Paint thickness	150 µ

* Calculated speed at 20° C



Grapple leg foot, European standard.

All specifications are subject to change without notice. A list of options enables you to adapt the product more precisely to your needs and further information is available on request.

HEAD QUARTER AND PRODUCTION

ELME Spreader AB

Phone +46 476 558 00
Email sales@elme.com

SALES AND SPARE PARTS

ELME Spreader Trading (Shanghai) Co., Ltd

Phone +86 21 5169 8922
Email sales.cn@elme.com

SPARE PARTS

ELME Americas Inc.

Phone +1 731 588 02 20
Email sales.us@elme.com

For details, spare parts and more products, visit www.elme.com.

ELMETM
Swedish Spreader Systems