

MODEL 817

TOP LIFT SPREADER FOR LADEN CONTAINER
HANDLING WITH REACH STACKERS

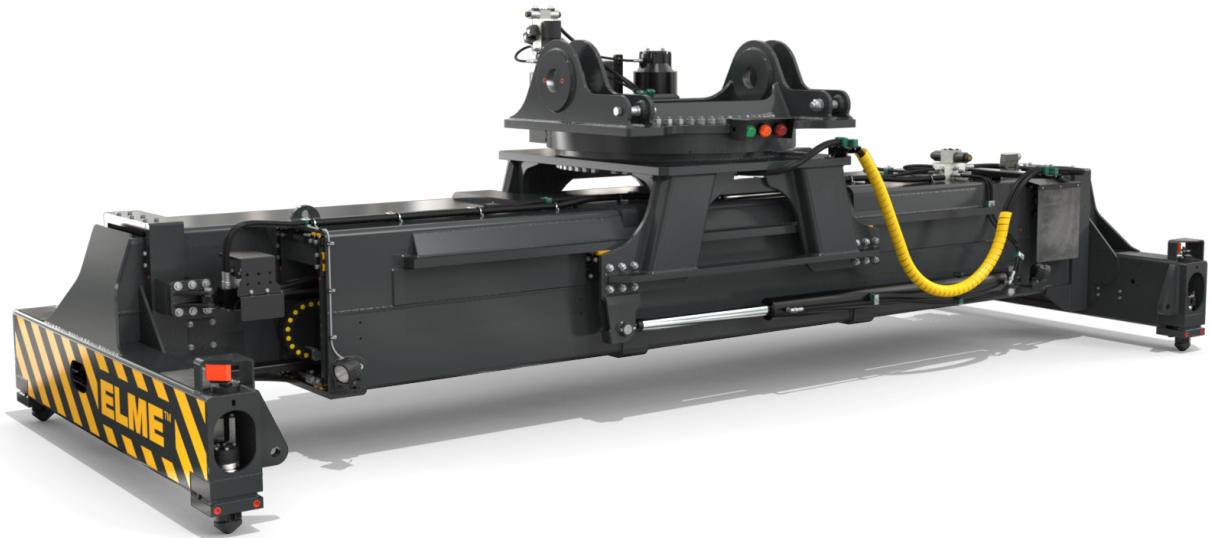

Standard supply includes:

- Mounting arrangement to fit the boom head
- Mechanical pile slope (MPS)
- Four vertical pendular ISO twistlocks
- Lifting eyes near twistlocks
- Hydraulic telescoping
- Hydraulic sideshift
- Hydraulic rotation
- Solenoid valves for all hydraulic functions
- Electrical and mechanical twistlock protection and indication system
- Electric telescoping protection system
- Lift interrupt signal
- LED-indication lights
- LED-work lights

ELME Spreader Model 817 is a telescopic top lift spreader for handling of laden ISO containers weighing up to 45 tonnes. 817 is designed for mounting on reach stackers.

The strong and basic concept offers distinct advantages, such as two parallel telescopic beams, assuring max overlap. Beam sections dimensioned to absorb not only the vertical, but also the very considerable horizontal forces.

TWISTLOCK SYSTEM

The twistlock system is manufactured in a rugged design and is well-proven since many years. 817 has hardened ISO quick exchange pendular twistlocks. Hydraulically activated and mechanical interlocking against faulty locking and unlocking.

TELESCOPING, SIDESHIFT AND ROTATION SYSTEM

Telescoping is powered by one hydraulic cylinder inside each beam. Sideshift is executed by two hydraulic cylinders on the outside of the

mainframe. Rotation is done by a slewing ring with double transmissions for turning and brakes for holding.

CONTROL AND PROTECTION SYSTEM

Electrical systems monitor the state of the spreader at all times. Indicator lights advise the operator when the spreader is correctly seated, locked or not locked. Each signal is a precondition for the important protection functions of the spreader. Such as twistlock activation, telescoping and lift interrupt.

MODEL 817

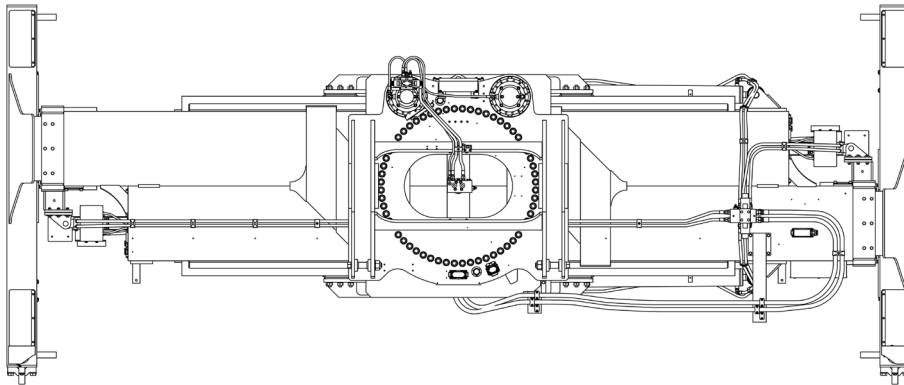
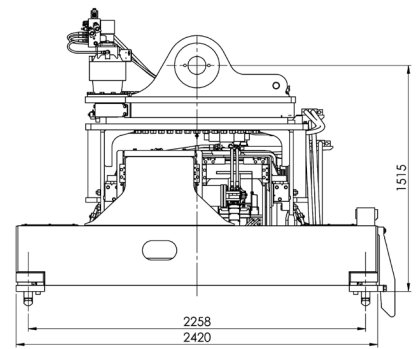
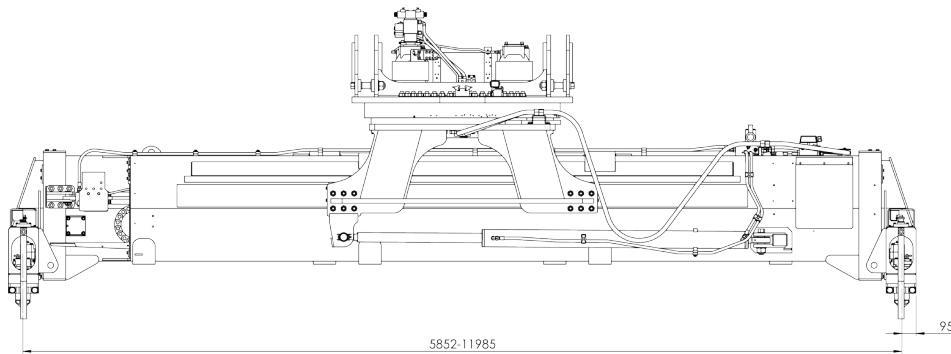

817.

TECHNICAL SPECIFICATIONS

Type of lifting system	Four vertical twistlocks
Spreader weight (TW)	9 300 kgs without extra equipment
Lifting capacity (SWL), spreader	45 tonnes \pm 10 % eccentric load
Lifting capacity (SWL), lifting eyes	4 x 11,25 tonnes
Twistlock	ISO pendular 20 mm
Telescopic positions	20 and 40ft
Telescoping speed, 20-40ft	< 20 sec.*
Telescoping speed, 40-20ft	< 25 sec.*
Rotation, 105° CW/195° CCW	< 42 sec. between endpoints*
Sideshift, \pm 800 mm	< 26 sec.*
Mechanical pile slope (MPS)	\pm 2°
Hydraulics, operating pressure up to	140 bar
Hydraulics, flow	40-60 L/min
Electric - control voltage	24 VDC
Colour	Black grey RAL 7021
Paint thickness	150 μ

* Calculated speed at 20° C



Twistlock and lifting eye.



Rotator.

All specifications are subject to change without notice. A list of options enables you to adapt the product more precisely to your needs and further information is available on request.

HEAD QUARTER AND PRODUCTION

ELME Spreader AB

Phone +46 476 558 00
 Email sales@elme.com
 Website www.elme.com

SALES AND SPARE PARTS

ELME Spreader Trading (Shanghai) Co., Ltd

Phone +86 21 5169 8922
 Email sales.cn@elme.com

SPARE PARTS

ELME Americas Inc.

Phone +1 731 588 02 20
 Email sales.us@elme.com

For details, spare parts and more products, visit www.elme.com.

ELMETM
 Swedish Spreader Systems